



HM

Jumbo Freezer and Ice Cream Freezer

500 S. Falkenburg Road
Suite 200 | Tampa, FL 33619
800.441.4014 | 813.870.0340
www.excellenceindustries.com

The company reserves the right to change the design and/or specifications of these products without notice. Printed in the USA.
Current version 01.20

KEY ASPECTS

SPECIAL FEATURES:

- 8 Baskets with 3 dividers each included
- High efficiency compressor
- Casters standard with 2 locking
- Environmentally friendly hydrocarbon refrigerant

OPTIONS:

- False bottoms (special order)
- Graphics
- Partitions (special order)

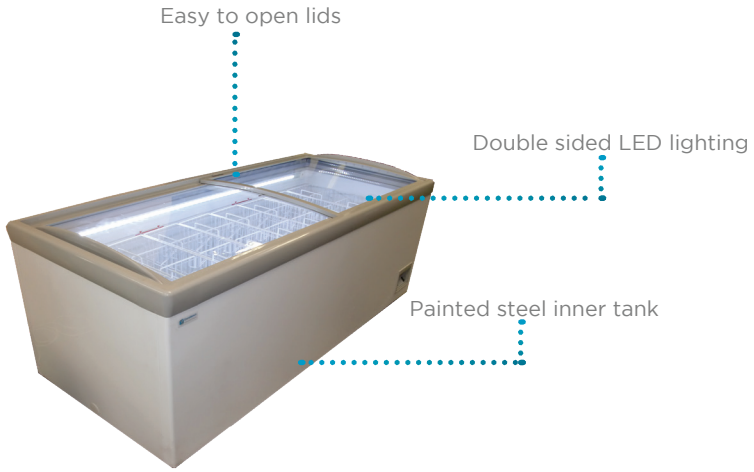

Complies with 2017 DOE standards for commercial freezer and ice cream freezer

TECHNICAL SUMMARY

MODEL	SIZE				ELECTRICAL		REFRIGERATION		OTHER	
	Dimensions (inches)* Width x Depth x Height	Cubic Feet	Net Weight (lbs.)	Shipping Weight (lbs.)**	Voltage/Hz/Phase	Running Amps	Compressor HP	Refrigerant	Temperature	Container Quantity
HM-23HC	73 7/8 x 32 1/2 x 33 1/8	23.3	229	287	115/60/1	5.5	3/4	R-290	-15° to +15°F	39

*Dimensions are all nominal lengths

**Does not include weight of pallets when needed

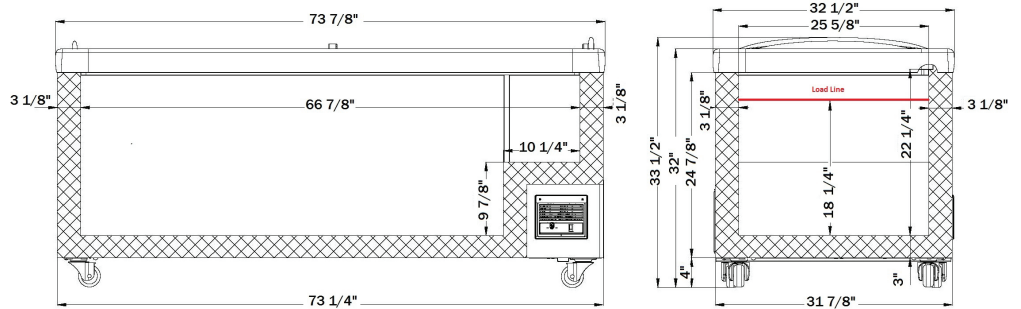

500 S. Falkenburg Road
Suite 200 | Tampa, FL 33619
800.441.4014 | 813.870.0340
www.excellenceindustries.com
ver. 01.20