



115 Volt!

PGC

Gelato Dipping Cabinet

KEY ASPECTS

SPECIAL FEATURES:

- Self defrosting
- Rear pivoting door
- Electronic control board
- Refrigerated storage compartment
- Modern design ideal for impulse sales

OPTIONS:

- Graphics
- Dipperwell

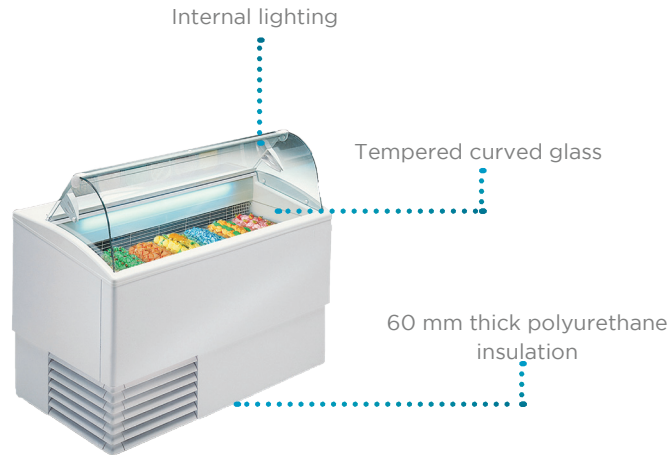

Additional storage compartment



Understorage



Complies with 2017 DOE standards for commercial freezer service over counter

TECHNICAL SUMMARY

MODEL	SIZE	ELECTRICAL		REFRIGERATION			OTHER					
	Dimensions (inches)* Width x Depth x Height	Net Weight (lbs.)	Shipping Weight (lbs.)**	Voltage/Hz/Phase	Running Amps	Compressor HP	Refrigerant	Temperature	Defrosting	5 L Pans Displayed	5 L Pans Stored	Container Quantity
PGC-6	47 x 31 1/2 x 46	214	276	115/60/1	9.2	1	R-404a	-3° to +10°F	Auto	6	14	44
PGC-7	53 1/2 x 31 1/2 x 46	225	289	115/60/1	8.2	1	R-404a	-3° to +10°F	Auto	7	19	32

*Dimensions are all nominal lengths

**Does not include weight of pallet when needed

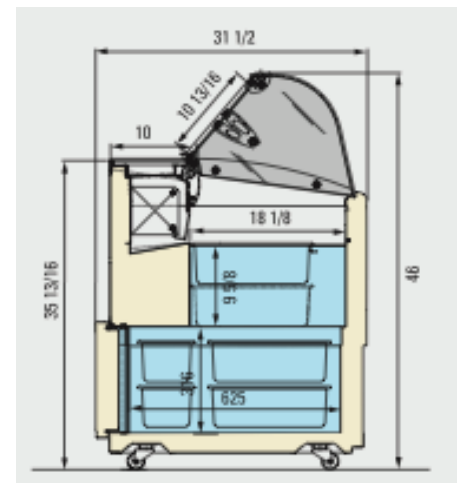

500 S. Falkenburg Road
Suite 200 | Tampa, FL 33619
800.441.4014 | 813.870.0340
www.excellenceindustries.com
ver. 05.20