



SPOT

Dual Temperature Merchandiser

KEY ASPECTS

SPECIAL FEATURES:

- Standard with wire shelf
- Adjustable thermostat
- Painted steel interior
- Casters with 2 locking

OPTIONS:

- Graphics

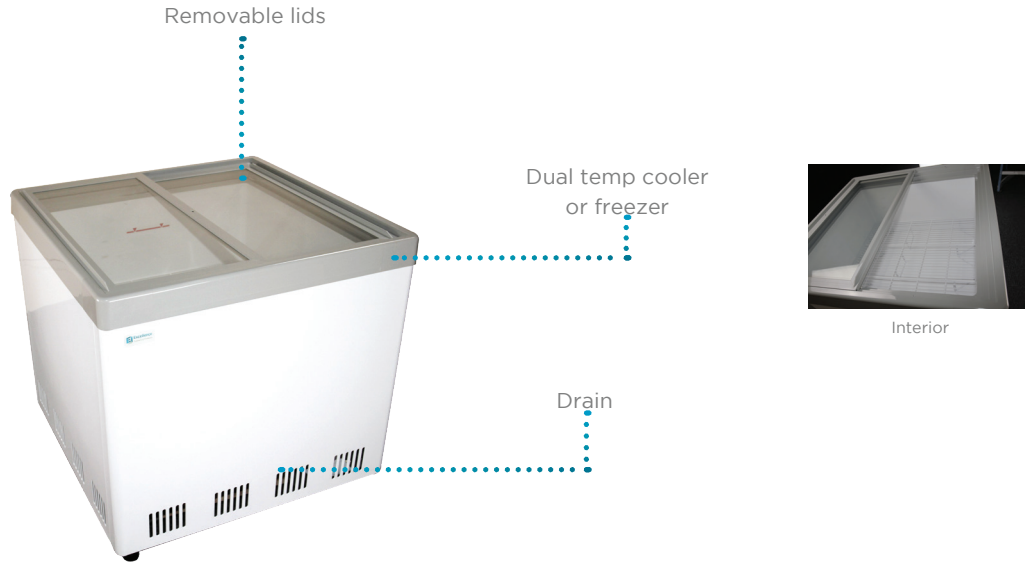

Complies with 2017 DOE standards for commercial cooler and freezer with or without doors

TECHNICAL SUMMARY

MODEL	SIZE Dimensions (inches) Width x Depth x Height	ELECTRICAL				REFRIGERATION			OTHER				
		Cubic Feet	Net Weight (lbs.)	Shipping Weight (lbs.)**	Voltage/Hz/Phase	Running Amps	Max KWh/24hr	Max KWh/24hr Open	Compressor HP	Refrigerant	Temperature	No. of 12" Facings	Container Quantity
SPOT-4HC	35 1/2 x 35 1/2 x 34 1/4*	8.3	148	176	115/60/1	1.4	1.2	3.5	1/3	R-290	0°F to +40°F	4	48
SPOT-6HC	47 1/4 x 35 1/2 x 34 1/4*	11.5	172	207	115/60/1	2.0	1.6	4.1	1/3	R-290	0°F to +40°F	6	42

*Add 2" for casters

**Does not include weight of pallets when needed

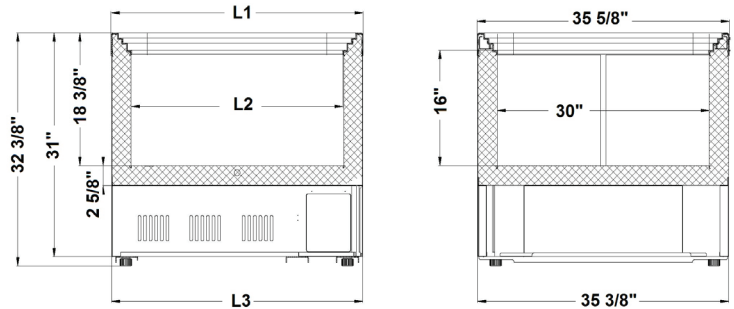

MODEL	L1	L2	L3
Spot 4	35 5/8"	30"	35 1/2"
Spot 6	47 5/8"	41 3/4"	47 1/4"

